

# “STAFFORD FC5”

## 5 INCH GAUGE 0-4-0

5 inch gauge super power! Based on our proven “Stafford” running gear, “FC5” brings a unique package of adhesive weight, tractive effort and all-round performance to the most demanding ground level 5 inch gauge applications - for garden, club or commercial use



Based on typical industrial narrow gauge practice, “Stafford” has been developed as a powerful, robustly-engineered locomotive, easy to drive for beginners yet having ample performance for extended club running.

From experience gained in repairing and servicing many hundreds of engines over the years in our workshop, key design considerations have been ease of maintenance, provision of generous bearing surfaces and use of high quality materials throughout - all contribute to an engine that will give many years of trouble-free service.

- Designed & built in the UK 
- 5 inch gauge
- EN8 steel wheels, roller bearing axleboxes
- Steel CE-marked boiler, working pressure 120psi, fitted with fusible plug
- Boiler feed by twin 2 1/4 pint injectors
- Walschaert’s valve gear
- Stainless steel water tank
- Weight 460 pounds
- Cast iron cylinders
- Supplied fully assembled, painted and tested, with owners handbook and 12 months warranty

With modern, CNC-equipped workshops near Lincoln, Station Road Steam has over ten years experience in the supply of high quality engines of all types, from 3 1/2 inch gauge locomotives right through to half-sized traction engines. We enjoy a fine reputation for our straightforward way of doing business backed by a “no quibble” guarantee.

Extensive investment in new machinery, state of the art design software and talented people is an on-going process, our aim is to produce high quality, ready-to-run models at a price that represents excellent value for money.

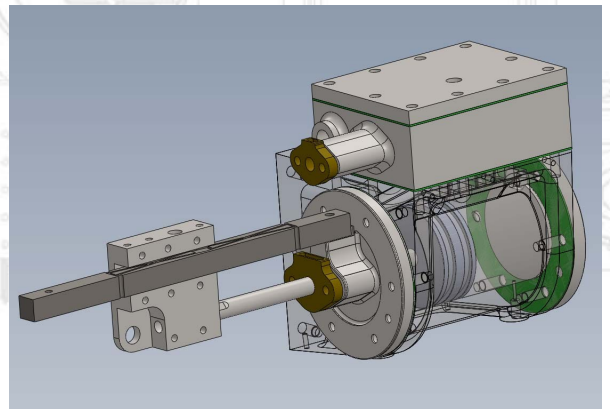

**Available ready to run or in fully-machined kit form to build yourself**

Station Road Steam Ltd, Unit 16-17 Moorlands Industrial Estate, Metheringham, Lincs LN4 3HX

Tel: +44 (0)1526 328772 [www.stationroadsteam.com](http://www.stationroadsteam.com)

[info@stationroadsteam.com](mailto:info@stationroadsteam.com)

<b>Technical specification</b>	
<b>Dimensions</b>	
Size	45 x 19 x 32 inches, L x W x H
Weight	460 pounds dry, 530 pounds ready-to-run
Nominal tractive effort	238 pounds
Minimum radius	20 feet
<b>Cylinders</b>	
Material	Cast iron
Bore/stroke	2 1/4 x 3 inches
Pistons	Cast iron, fitted two Clupet rings
Lubrication	Mechanical lubricator
Drain cocks	Mechanical, rod-operated from footplate
Valve gear	Walschaert's, pole reverser on footplate
<b>Boiler</b>	Welded steel, expanded steel tubes, fitted fusible plug
Working pressure	120 psi
Safety valve	Bronze pop-type
Water feed	Twin injectors
Maintenance	3/8 BSP blowdown valve beneath firebox
	3/8 BSP washout plug in throatplate
	3/4 BSP washout plug in front tubeplate
Wheels	EN8 Steel, 6 1/2 inch diameter, sealed bearing axleboxes
Coupling multi-height	10mm pin coupling on drag beam
Water tank	Stainless steel, TIG-welded, 4 gallon capacity
Finish	Standard colour two-pack RAL6007 green
	Chassis black, buffer beams red
Brakes	Screw down mechanical brake acting on rear wheels
<b>Options</b>	
Whistle	
Vacuum train brake	Ejector, steam valve, vacuum gauge, driver's brake valve
Finish	Non-standard colour
Accessories	Braked driving truck

New engines can normally be viewed at our works by appointment. Part exchanges are welcome, crating and worldwide delivery can be arranged.

Station Road Steam Ltd, Unit 16-17 Moorlands Industrial Estate, Metheringham, Lincs LN4 3HX  
 Tel: +44 (0)1526 328772 www.stationroadsteam.com info@stationroadsteam.com